



# Digital Dimmer Unit with RCK system

## Instruction Manual

Models:

DDP1210 RCK, DDP1213 RCK, DDP1216 RCK  
DDPN1210 RCK, DDPN1213 RCK, DDPN1216 RCK  
DDP6025 RCK, DDP6032 RCK  
version 4.0 since 3 February 2020

### ATTENTION!

This instruction manual contains important information about the installation and the use of the equipment. Please read and follow these instructions carefully.

Always ensure that the power to the equipment is disconnected before opening the equipment or commencing any maintenance work.

## **General information**

### ***IMPORTANT INSTRUCTIONS!***

All safety and operating instructions should be read before the equipment is installed or operated.

This equipment must be earthed.

Let the equipment adapt the environment for at least 10 minutes after unpacking.

### ***IMPORTANT SAFETY INFORMATION***

The following general safety precautions have to be observed during all phases of operation, service, and the repair of this equipment. Failure to comply with these precautions or with specific warnings in this manual violates safety standards of design, manufacture, and the intended use of this equipment.

#### ***Do not operate in an explosive atmosphere!***

Do not operate this equipment in the presence of flammable gases or fumes. Operation of any electrical instrument in such an environment constitutes a definite safety hazard.

#### ***Water, moisture, heat and humidity***

Do not operate this equipment near water or in areas with wet floors, or in high humidity atmosphere, where condensation forms on the equipment. It should never be placed near or over a heat register or other source of heated air. It should not be installed or operated without proper ventilation.

#### ***Power & DMX Input connections***

Power & DMX Input connections are done using a HARTING connector located on the right side of the rear panel. Simply roll the dimmer pack along the wheels and plug it in the back panel by a slight push.

#### ***Output connection***

The output terminals are located inside the dimmer and are wired to the HARTING connector located on the left side of the rear panel. Live, neutral and earth connections must be made to all load equipment.

# Functions and Control

## Front panel:

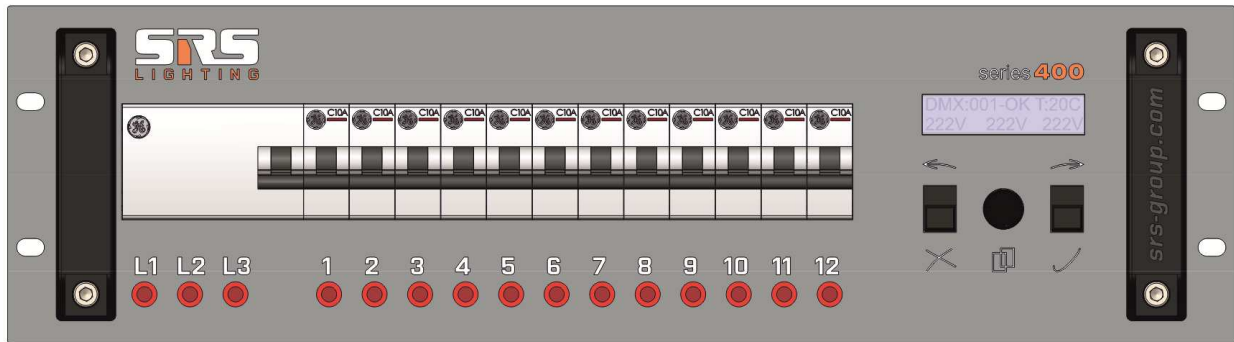

1. GF163 or 80A, 30mA / \*main switch – B models
2. Indicator of main input
3. Circuit breakers **1P** for DDP model and **1P+N** for DDPN model
4. Output load indication /off when the lamp connection and channel level are set to zero/
5. ESC button
6. ENCODER
7. ENTER button

## Rear panel:

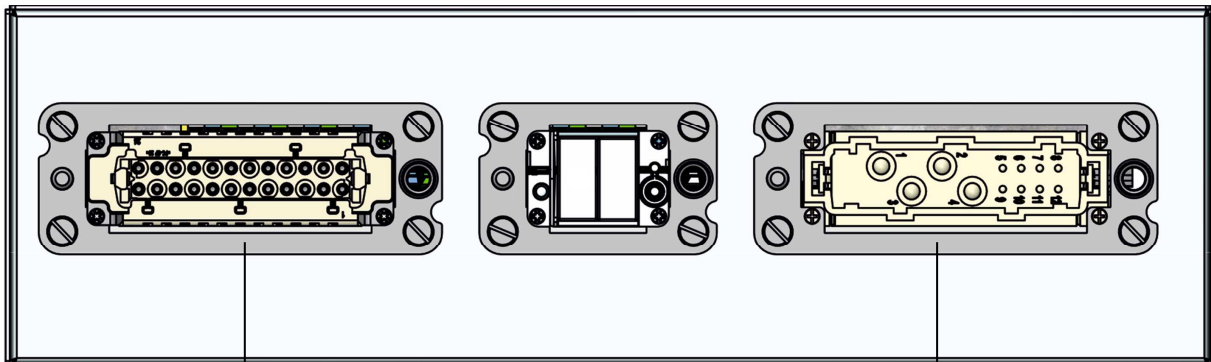

Dimmer OUTPUT connector

Dimmer Power input and DMX connector

**RCK model**

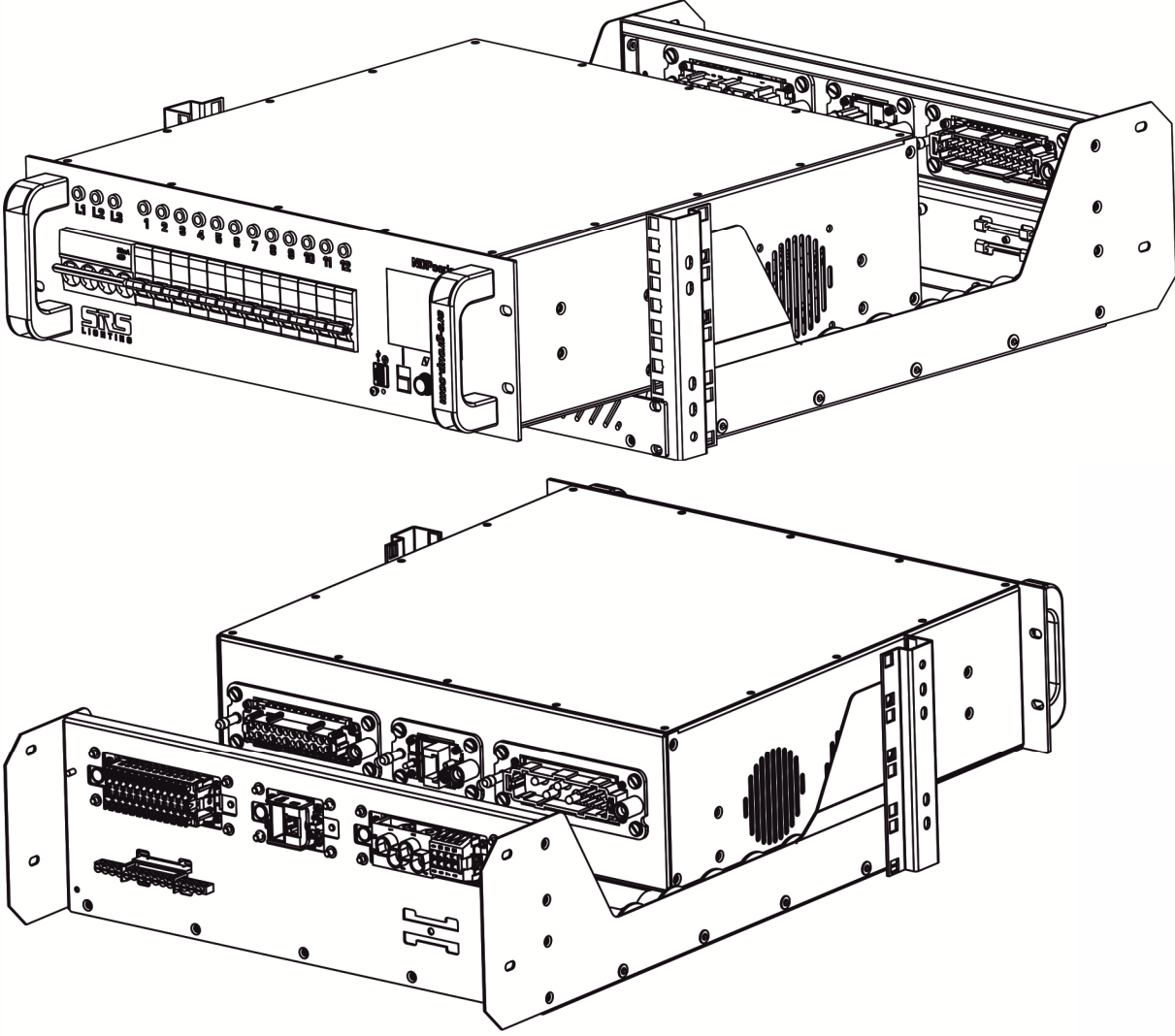

# RCK system specifications

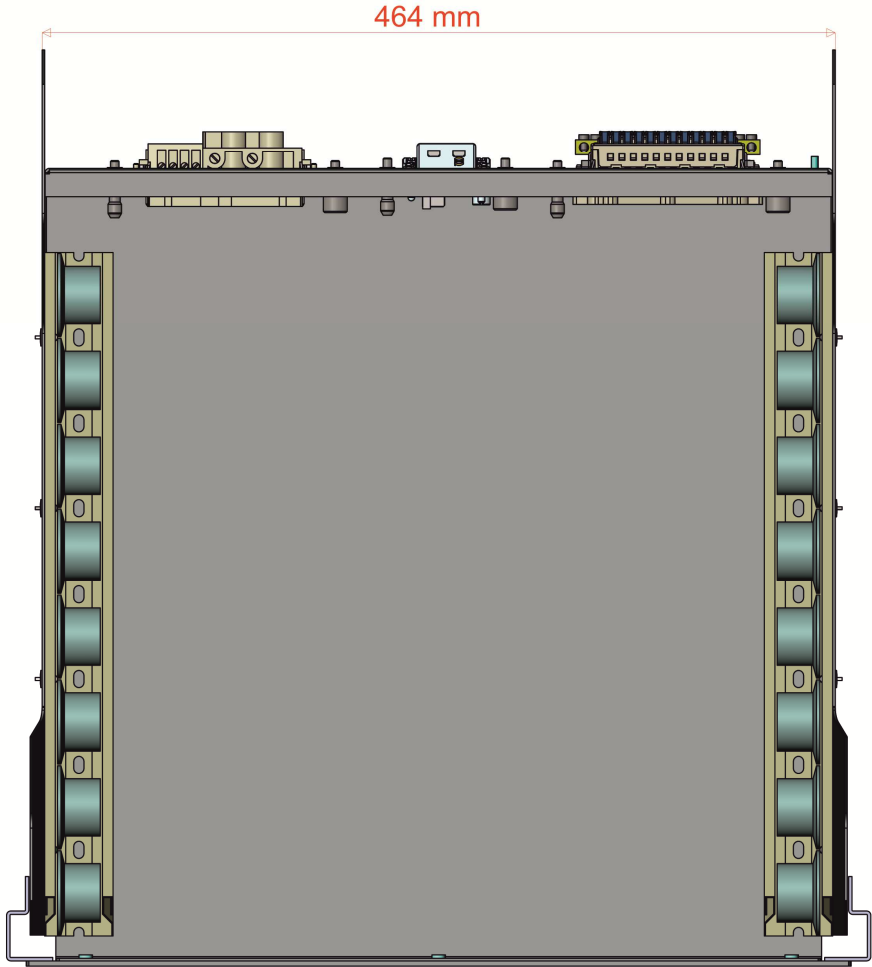
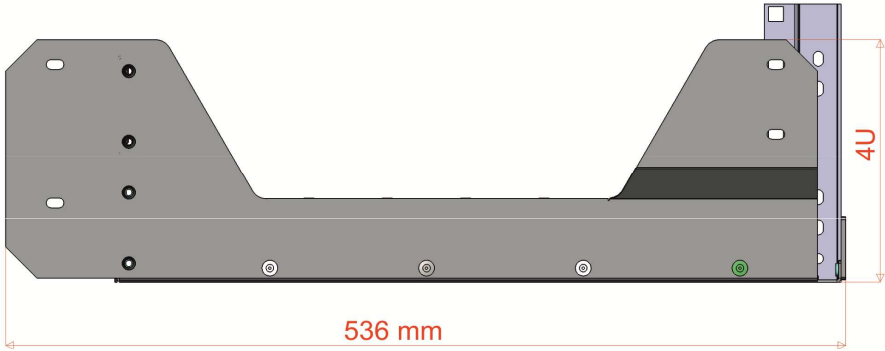
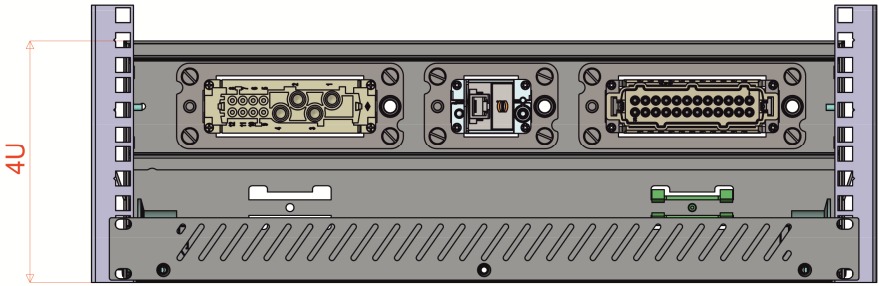

## Navigation menu

The initial menu indicates the DMX start address, DMX status, inside dimmer temperature and main voltage.

### **DMX status:**

NC DMX is not connected  
ER swap 2 and 3 on the DMX cable  
OK DMX is OK

```
DMX: 216-NC T: 37C  
228V 230V 231V
```

```
DMX: 216-OK T: 37C  
228V 230V 231V
```

```
DMX: 216-ER T: 37C  
228V 230V 231V
```

### **Temperature status:**

# Number shows the temperature of dimmer in °C  
OL! Warning: The inside temperature of the dimmer is higher than 75°C.  
Outputs are switched off.

```
DMX: 216-OK T: 37C  
228V 230V 231V
```

```
DMX: 216-OK T: OL!  
228V 230V 231V
```

Rotate the ENCODER to see the output bargraph.



### **Menu navigation:**

Press the ENCODER to enter the main menu.

Rotate the ENCODER and select one of the following items by pressing it:

1. START ADDRESS
2. PREHEAT
3. CURVE
4. AUTOMATIC TEST
5. LOCK CONTROLS
6. LIMIT OUTPUTS
7. SETUP /to enter the SETUP, press the ESC and ENTER buttons at the same time/
  1. DMX MODE
  2. ANALOGUE MODE
  3. MANUAL MODE
  4. MIX MODE
  5. PATCH
  6. SCENE
  7. LOST DMX
  8. FACTORY RESET

## Set the DMX address



Press the ENTER button.

Rotate the ENCODER to set the DMX start address (001-512). Press the ENTER button to confirm.

## Preheat

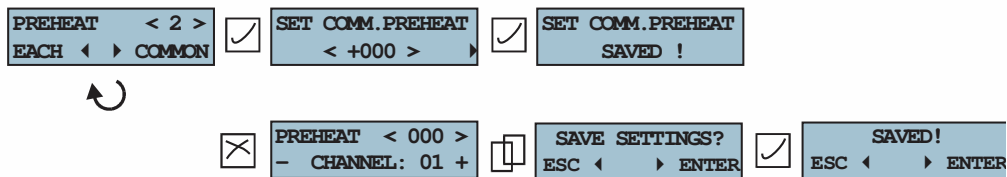

Press the left button to select preheats for every channel individually or the right button to set one common preheat for all channels. If necessary, use preheat 0-100% for a fast control of the dimmer output.

## Dimmer curves

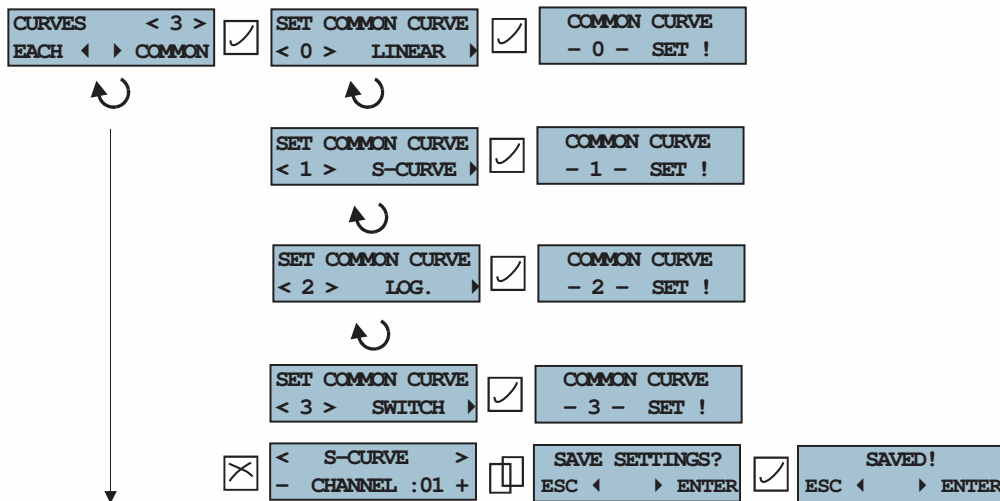

Press the left button to select the curves for each channel individually or the right button to set one common set of curves for all channels.

## Automatic lamp test

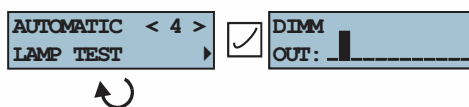

Press the ENTER button to start the test.

Every channel will be tested by increasing/decreasing the output value per channel.

## Lock Code

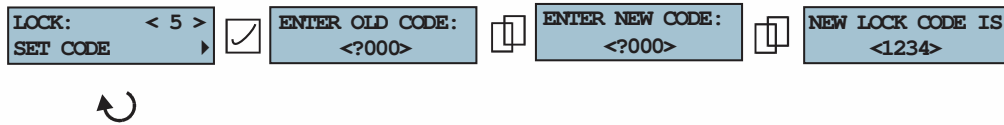

Enter the old code (factory setting is 0000). Press the ENCODER button.  
Enter a new code and press the ENCODER button. The new code is now saved. To lock the menu, press both buttons at the same time. To unlock the menu, press the ENCODER and enter the code. The menu is now unlocked. If you need to restore the code, please ask for service manual.

## Limits

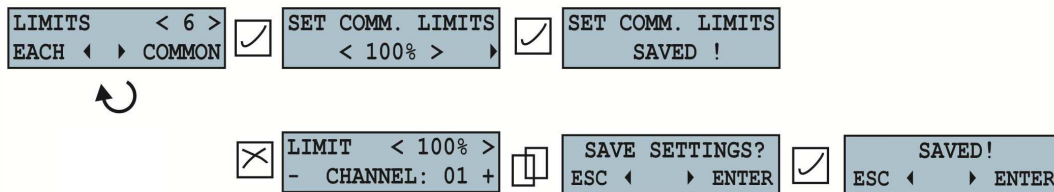

Press the left button to select the limit for each channel individually or the right button to set one common limit for all channels. Limit 100% means that output will go to 100%. Limit 50% means that outputs will go to 50% maximum. You can set the limit from 0-100%.

## Setup



Press the ESC and ENTER buttons at the same time to enter the SETUP MODE.

The dimmer has six modes of control:

- DMX mode /controlled by DMX/
- Analogue mode /controlled by 0-10V/
- Manual mode /controlled by menu of dimmer/
- Mix input mode /LTP or HTP rule/
- Patch mode
- Scene control

## DMX mode



Rotate the ENCODER and set the DMX address [001-512].  
Press the ENTER button to confirm.  
The dimmer works only with the DMX input now.



## Analogue mode 0-10V



Press the ENTER button.  
The dimmer works only with 0-10V control now.

## Manual mode



Press the ENTER button.  
The dimmer works only with manual control now. You can set output channel for each channel.

## Mix mode

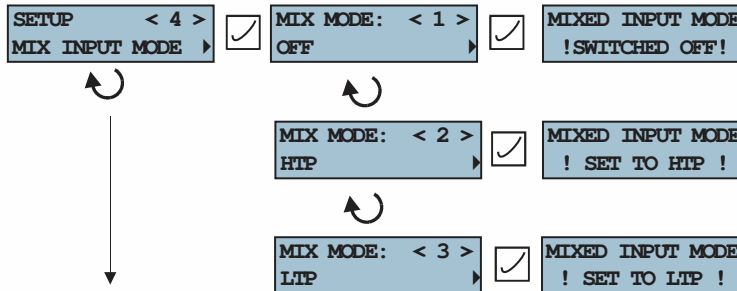

The dimmer is switched to the HTP or LTP mix mode now. In this mode, the dimmer is controlled via DMX and 0-10V input at same time.

## Patch mode



Press the right button to select the dimmer channel. Press the left button to select the control mode (DMX, analogue or manual mode) for each channel. Use the ENCODER to assign control mode for each channel.

## Scene mode

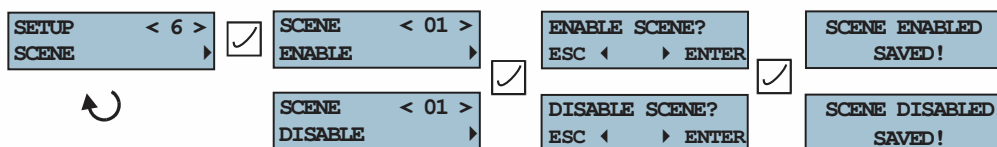

In menu scene, you can enable or disable the scene function. Press the ENTER button to confirm your selection.

## Flash scene

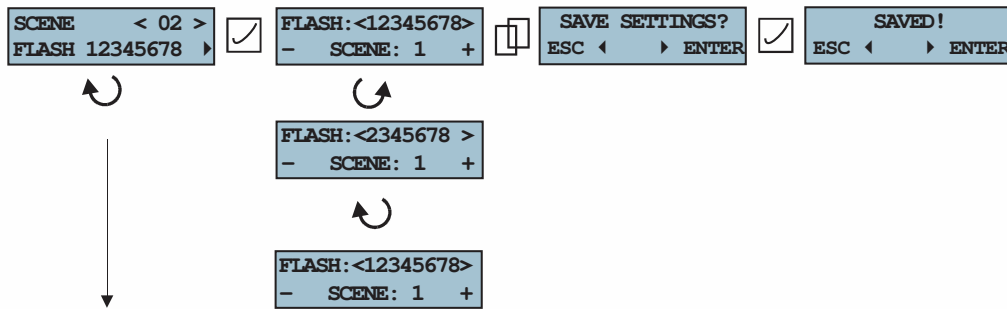

The flash scene is a scene mode, where scenes are called by a single press of a button. When any other button on the HLC is pressed, the other scene is called. You can preset up to 8 scenes. A scene that is to be flashed must be added to the Flash scene list. Rotate the ENCODER until you get to the desired scene number and confirm by the ENTER button. To remove a scene from the Flash scene list, rotate the ENCODER to the scene number and press the ESC button. A single press of the ENCODER saves all settings.

## Scene channel



The channel for scene call from the DMX console (as if it was from analogue input) can be set here. The scene is called when the channel value is set to one of ten values. Scene numbers and their channel value ranges are illustrated in the table below. For example, to call scene 1, channel 13 can be used.

The scene is called if fader is set in one of these values for more than 2 seconds. Value other than 0 blocks the scene call via analogue input, while value 255 cancels all scenes.

Scene #	Channel value range
1	10-19
2	20-29
3	30-39
4	40-49
5	50-59
6	60-69
7	70-79
8	80-89
9	90-99
10	100-109
11	110-119
12	120-129
13	130-139
14	140-149
15	150-159

**Note:** If the MIX INPUT MODE (SETUP <4>) is turned off, the selected channel does not cancel the scene call.

## Scene fade speed

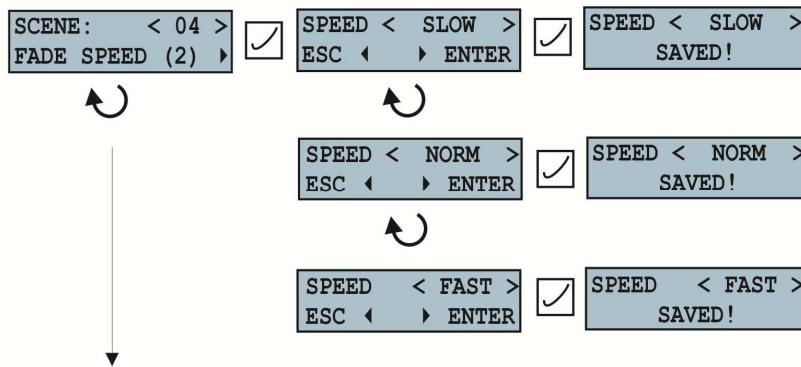

The fade speed can be set in three timeframes: SLOW, NORMAL or FAST. According to the setup, the scene will be changed to the selected speed when the scene is called.

## Save output of dimmer to scene

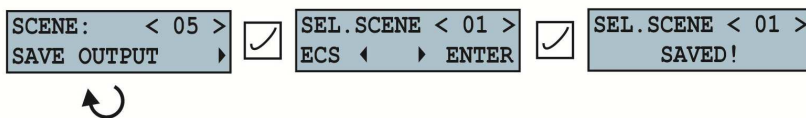

The output of dimmer can be easily saved to any scene. This means that actual light output from dimmer can be saved to a scene and called later remotely. Select scene by rotating the ENCODER and save it by the ENTER button. This value will then be processed by a curve. If preheat on the channel is later changed, the scene will remain unchanged.

## Set up the scene manually

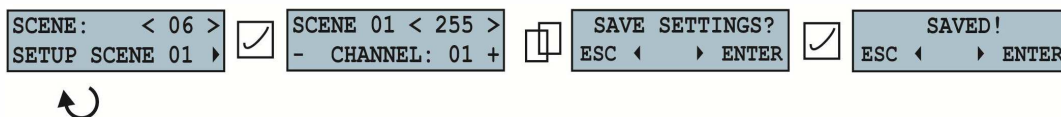

Up to 15 scenes in the dimmer can be set up/recorded and their LATCH/FLASH function can be selected. Use ESC/ENTER button for scrolling over channels and the ENCODER for the selection of channel value and its confirmation. Then set up the output levels for each scene individually and confirm by pressing the ENTER button.

## DMX lost setup

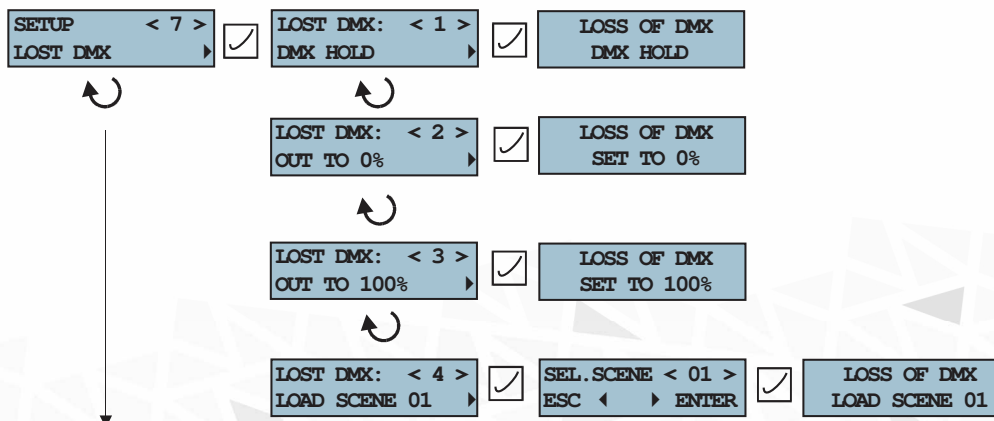

There are four options to set if the DMX signal from DMX port is disconnected:

- Outputs will hold the last DMX data frame.
- Outputs will fade to zero.
- Outputs will go to 100%.
- Outputs will be changed to a selected SCENE (0-15).

## Factory reset



The following are the factory defaults:

- DMX mode
- DMX start address: 001
- Preheat: 000
- Curve 01: linear
- Mixed mode: OFF
- Limits: 100%
- Lock code: 0000
- Scene: disabled
- All scenes are erased
- Flash scene: 1-8
- Latch scene: 9-15
- Fade speed: NORM
- Lost DMX: hold active

## Service menu

Contact your distributor or manufacturer to get the code to enter the service menu. In this menu, you are able to change the type of dimmer. You can set up the new lock code if the old one has been lost or calibrate the voltage metering and the global preheat.

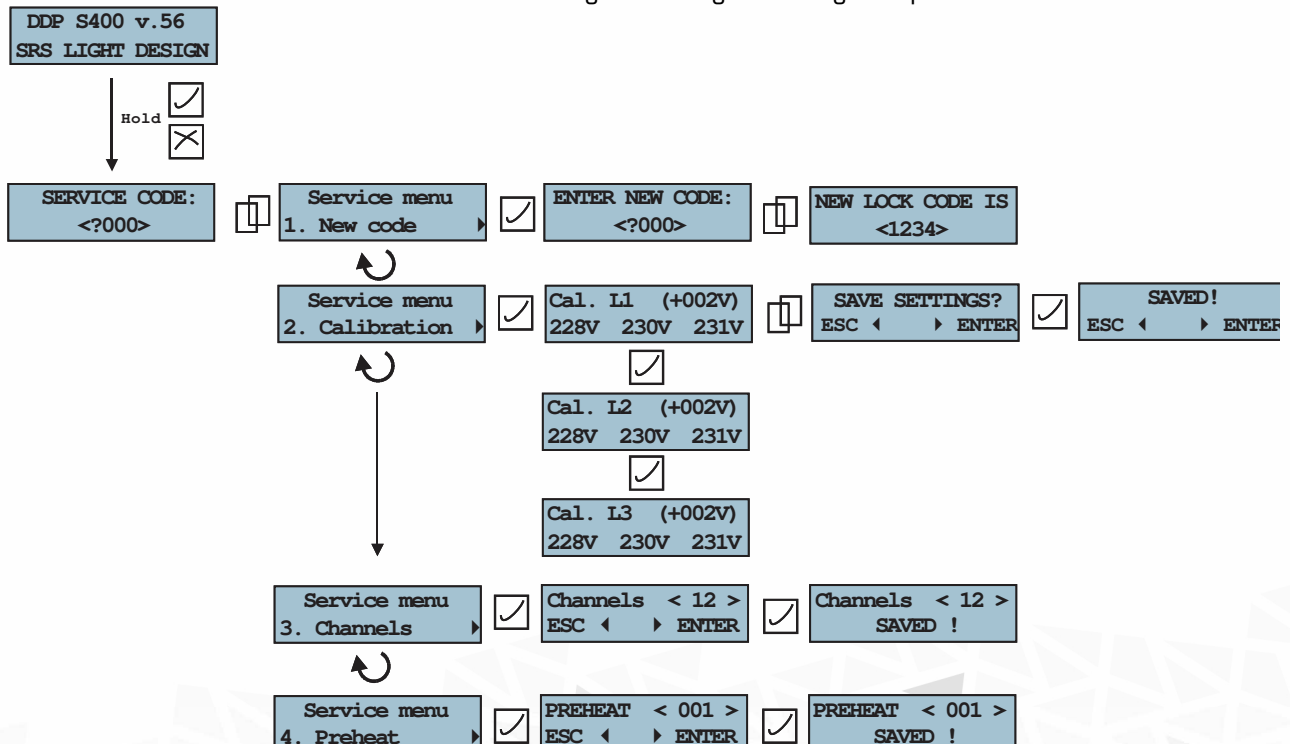

# Menu tree

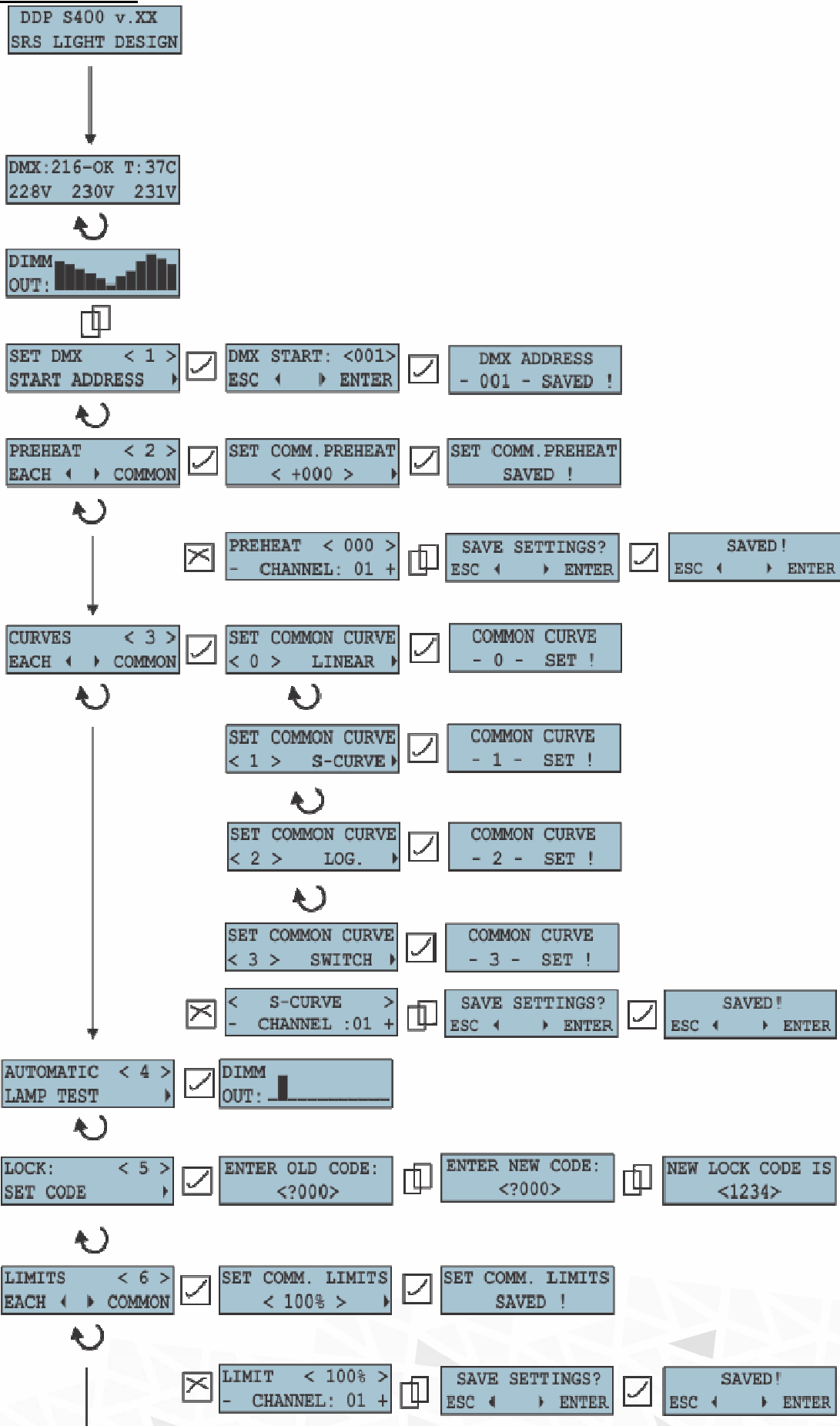

# Setup menu tree

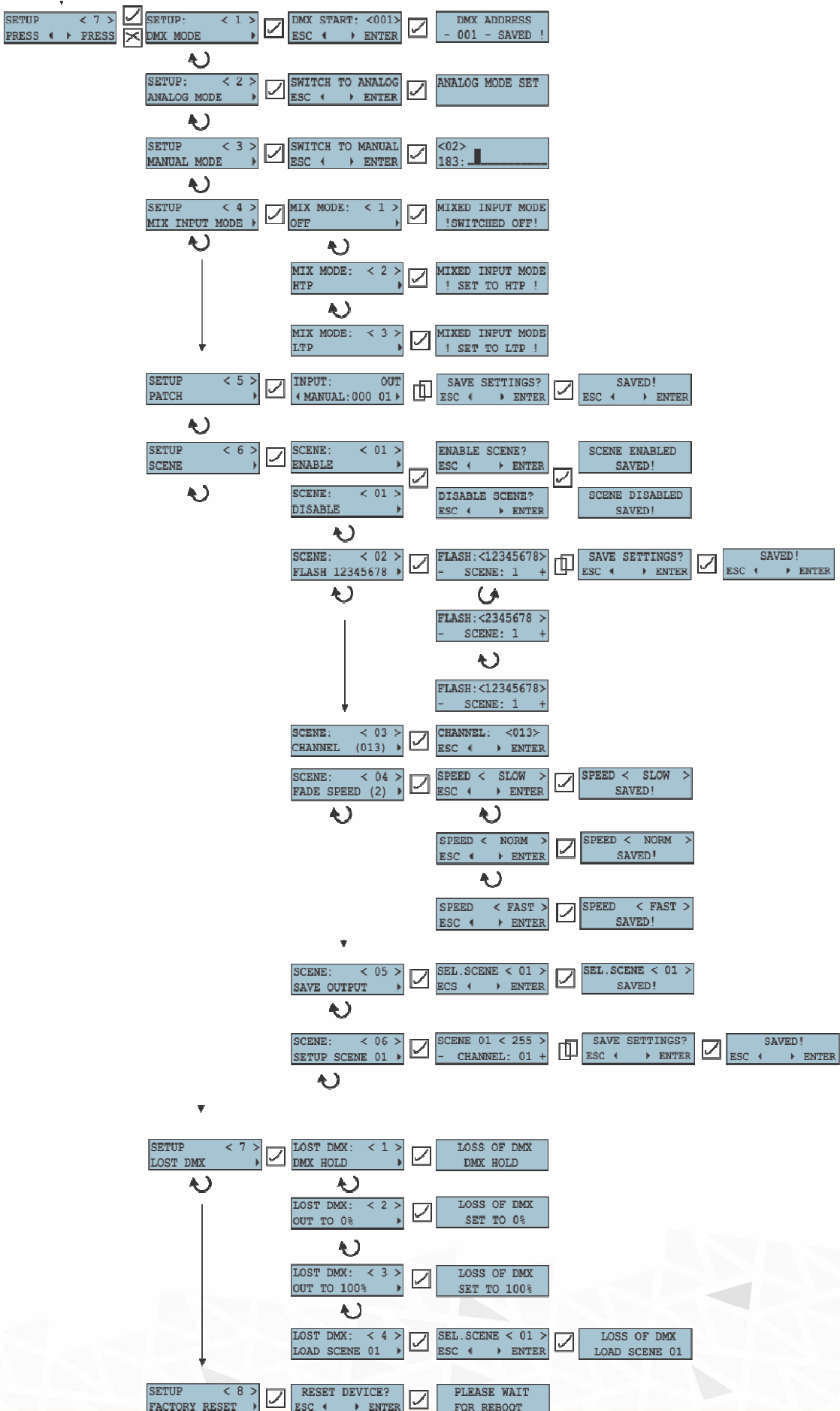

## **Technical data**

### **Dimming capacity**

DDPx1210 RCK	12x10A	12x2.3kW
DDPx1213 RCK	12x13A	12x3kW
DDPx1216 RCK	12x16A	12x3.7kW
DDPx6025 RCK	6x25A	6x5.7kW
DDPx6032 RCK	6x32A	6x7.3kW

### **DDP RCK Dimensions & Housing:**

436.5 x 132 x 438 mm, Steel housing with gray powder coating

### **Weight:**

DDP12xx RCK: 24 kg

### **Interference suppression:**

Phase-angle control with triacs and in-line precision filters: 400us

### **Protection:**

Short circuit protection by MCB  
Optional 1P+N, 1P+1P short circuit protection  
Double thermal protection

### **Ventilation:**

100% duty cycle  
Temperature-controlled fan  
Automatic shutdown at critical temperatures

### **Others:**

All safety features are displayed on the display  
Soft start  
Controlling of special functions via display, three keys and an encoder  
Circuit breakers on the front panel  
Easy change of power output connectors

### **Display Functions:**

Voltage of all 3 phases  
Single channel values  
Inner temperature  
Load status check  
DMX signal status

### **Digital menu functions:**

Preheat per channel  
Dimmer curve per channel  
Single channel patch  
Variable channel set  
DMX processing with fast output response  
Hold function for output in case of the DMX data failure



## Declaration of conformity

We hereby declare that the equipment described below conforms to its design, type and version introduced by us to the fundamental safety and health requirements of the EU Guidelines Machines.

Manufacturer:

SRS Group s.r.o  
Rybničná 36/D  
83107 Bratislava  
Slovakia

Declares that the product

Name of product: Digital dimmer pack series400  
Type/version: **DDP12xx RCK, DDPN12xx RCK**

Correspond to the specification:

EN 60-950-1:2003  
EN 55103-1:2000  
EN 55103-2:2000  
EN 60-598-2-17 1989 including amendments 1/2  
EN 60-598-1 1992 including amendment 1

CE marking directive 93/68 EEC  
Low voltage directive [2006/95/EG]  
EMC directive [2004/108/EWG]

Bratislava, 29 April 2011

Robert Sloboda

Copyright 2017 SRS Group, s.r.o. | Specifications subject to change without notice.  
Document: DDP12XX\_RCK\_en\_manual\_M286 | Version 4.0 | Actual as of: 3 February 2020



**SRS Group s.r.o.**

Rybnična 38/B | 831 07 Bratislava | Slovakia  
Phone: +421 2 32 661 800  
Email: [sales@srs-group.com](mailto:sales@srs-group.com) | [www.srs-group.com](http://www.srs-group.com)

