



Hoist / Motor Controller

Instruction Manual

Models:

MCP6-LV-6H6

version 3.0 since 3 February 2020

ATTENTION!

This instruction manual contains important information about the installation and the use of the equipment. Please read and follow these instructions carefully.

Always ensure that the power to the equipment is disconnected before opening the equipment or commencing any maintenance work.

General information

IMPORTANT INSTRUCTIONS!

All safety and operating instructions should be read before the equipment is installed or operated.

IMPORTANT SAFETY INFORMATION

The following general safety precautions have to be observed during all phases of operation, service, and the repair of this equipment. Failure to comply with these precautions or with specific warnings in this manual violates safety standards of design, manufacture, and the intended use of this equipment.

Do not operate in an explosive atmosphere!

Do not operate this equipment in the presence of flammable gases or fumes. Operation of any electrical instrument in such an environment constitutes a definite safety hazard.

Water, moisture, heat and humidity

Do not operate this equipment near water, in areas with wet floors or in high humidity atmosphere where condensation forms on the equipment. It should never be placed near or over a heat register or other source of heated air and it should not be installed or operated without proper ventilation.

Functions and Control

Motor Controller is designed to control up to 6 electrically compatible low voltage hoists separately or simultaneously; controlled via cable remote controller MCPx.MCBC REMOTE.

Each device is equipped with MPA /Manual Phase Align/ module that allow changing the phases easily by rotating pins L2 and L3 on the main connector. This helps to run the hoist in same direction as is required.

All electrical components carry their own individual CE and comply with European Directives. The components are mounted in robust 2.0mm steel with powder coating. This electronic board is mounted inside plastic case. Unit complies with the CE according to the Certification of Conformity that is attached to this manual.

MCP6-LV-6H6

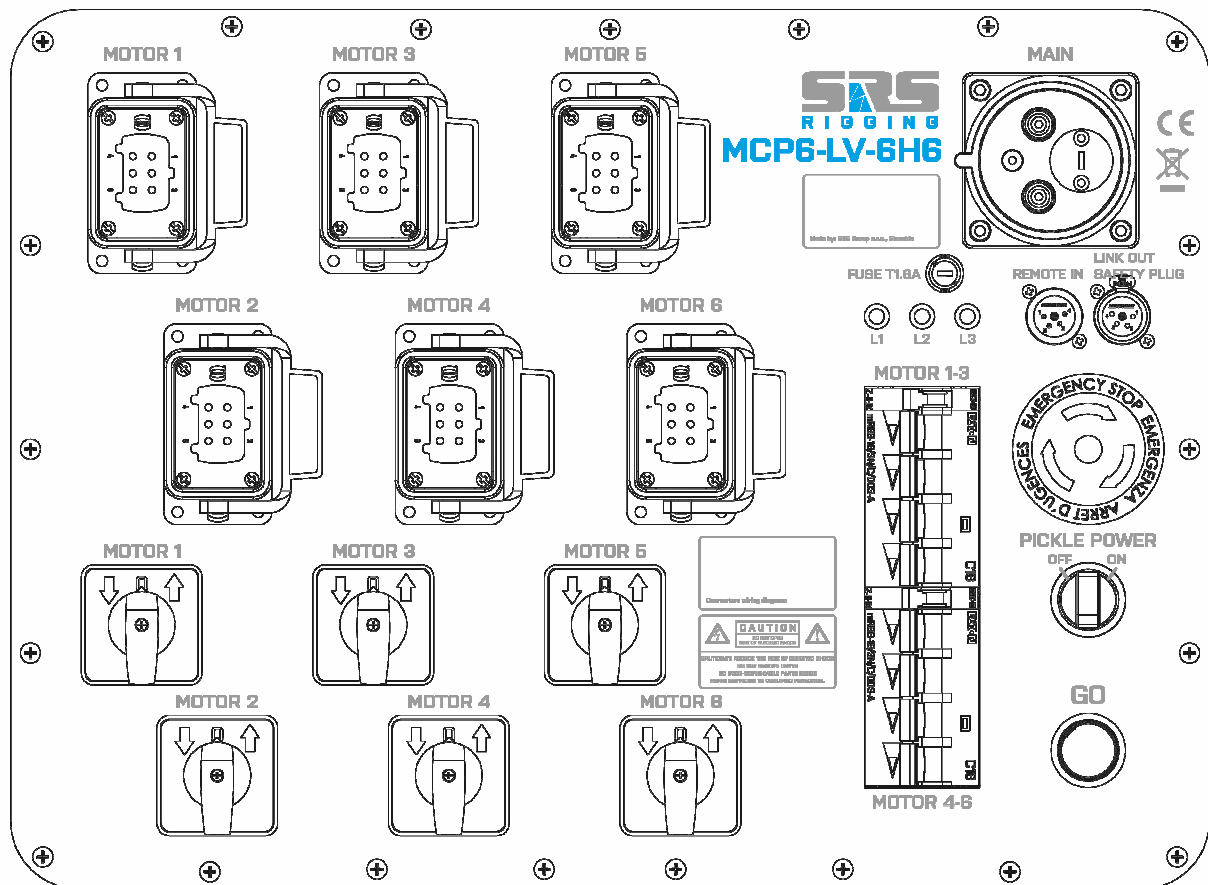

EMERGENCY STOP:

Emergency STOP is the red button located in the middle of yellow circle.

Emergency STOP button turns the MCP6-LV-6H6 controller to an inactive state and stays in it.

To release it, rotate the emergency stop clockwise.

When several more controllers are linked together, the press of any E-STOP button will shut down all connected controllers.

GO:

When active, the green pushbutton turns the selected channels of the Hoist Control system ON.

Once the GO button is released, the energizing of the hoists is turned off.

When several more controllers are linked together, the press of the first GO /MASTER/ in chain will run all hoist controllers.

LINK:

For linking of several controllers, use a 4-pin MC-x-LINK cable. Safety breach needs to be connected in the last controller of the chain. See schematics for details.

PICKLE POWER:

For using a power only on hoist use a pickle switch to connect the mains to the Socapex connectors. Pickle is working only when E-stop is not pressed. Pickle mode deactivates the using of GO button and direction switches too.

Operation

The Low voltage motors/hoists connected to the MCP6-LV-6H6 controller can be activated individually or simultaneously using the GO button located on the front panel, via cable remote or by linked controller. The selection of the hoists that are controlled is made using the switches located on the front panel.

Several MCP6-LV-6H6 controllers can be linked together to create bigger systems.

How to start

- Connect the CEE32A/5p plug to the AC400V power supply and check GFI and control MCBs.
- Connect the plugs of the electric hoists to the sockets of Socapex 19. Each Socapex 19 is used for combined power and control of 3x hoist
- Check if all emergency STOP buttons /on device and on all other linked devices in the system/ are released and there is the presence of security plug/breach with short circuit in between pins 3 and 4 on the last unit in system.

To Move a Single/Several Motor(s):

- Set the UP/DOWN switch for each motor to the desired direction.
- Hold the GO button until all motors are moved the desired height and release.

To use a Pickle Mode:

- Set the UP/DOWN switch for each motor to the middle position.
- Turn on the pickle mode by pickle selector. Use external direction pickles for work with hoist connected to controller.
- Pickle mode is working only when E-stop is not activated and safety plug is connected.

Controller normal operation:

In this mode, controller is operated by GO and E-STOP buttons located on the front panel.

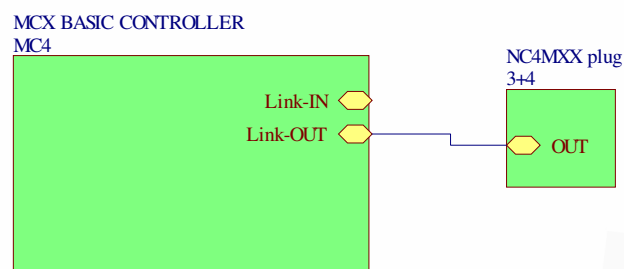

During operation, the NC4MXX plug must be connected to the last controller in chain

Controller with remote operation:

In this mode, controller is operated by GO and E-STOP buttons located either on the front panel or on the MCP6-LV-6H6 REMOTE.

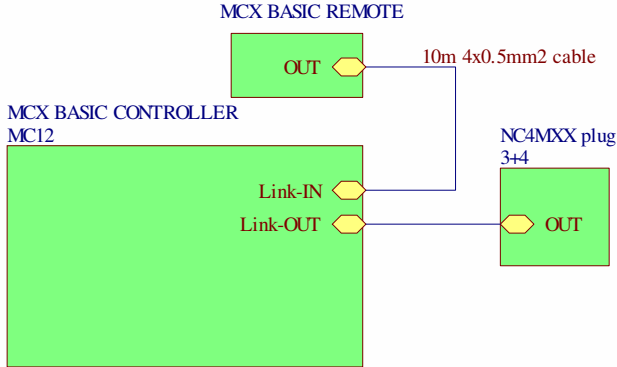

During operation, the NC4MXX plug must be connected to the last controller in chain

Controller link operation:

In this mode, all linked controllers are operated by any GO and E-STOP button located either on the front panel or on the MCP6-LV-6H6 REMOTE.

Do NOT forget to plug the NC4MXX plug to the last controller in chain.

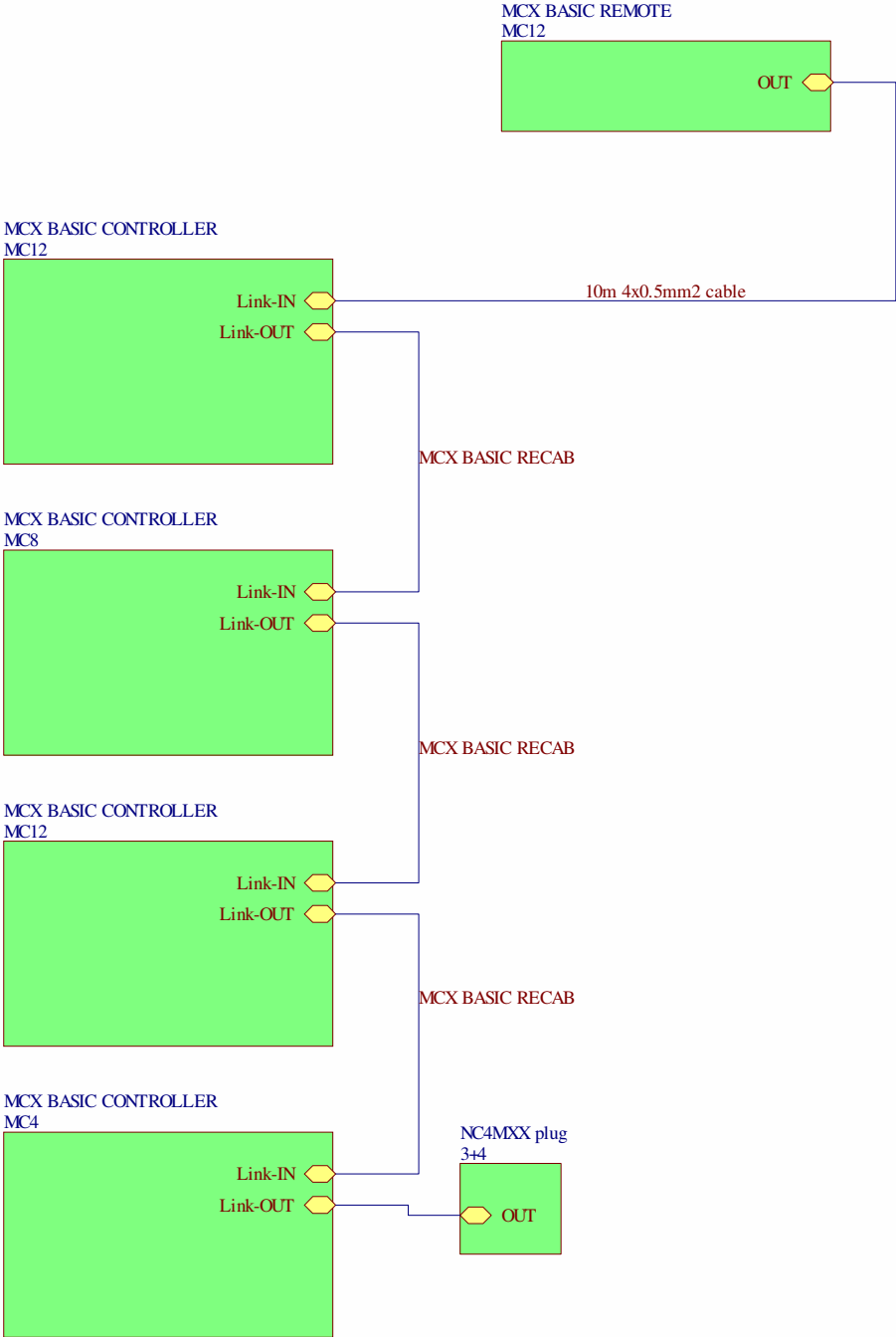

During operation, the NC4MXX plug must be connected to the last controller in chain

MCPx- REMOTE

Remote controller allows controlling of GO and E-STOP buttons for single controller or all linked controllers. Standard length of cable is 10m. The length can be altered according to the customer's needs. There is also a 1m cable for linking of controllers.



STOP:

This switch protects the base unit from undesired operation and turns the MCP6-LV-6H6 controller to inactive state. Stop button is of red color. Once the STOP button has been pressed, it is locked in an inactive position and must be rotated clockwise to be released.

GO:

When active, the pushbutton turns the selected channels of Hoist Control system ON. Once the GO button is released, the energizing of the hoists is turned off.

Description of connectors

LINK in/out connector

Lines 3 and 4 are normally closed – NC, by default for normal operation. Due to this, it is necessary to fit the safety breach /MXX connector/ to the link OUT connector with the short circuit between pins 3 and 4 for normal operation.

This breach must be connected to the last controller in system if the controllers are linked.

Neutrik NC4FXX

- Pin 1. Remote go in
- Pin 2. Remote go out
- Pin 3. Safety in
- Pin 4. Safety out

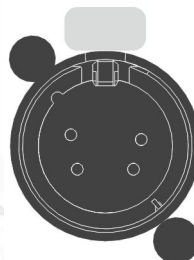

HARTING 6 female

Pin	Function	Note
1	L1	
2	L2	
3	L3	
4	COMMON	
5	UP	
6	DOWN	
BODY	PE/GROUND	

Protection and Safety:

- Input CEE32/5p
- 2x RCBO C16 +RCD 30mA linked
- MPA – Manual Phase Align
- Mains contactor rated to full power

Dimensions /W x D x H/ & Weight

MCP6-LV-6H6: Plastic case: 503 x 406 x 193 mm, weight: 12kg

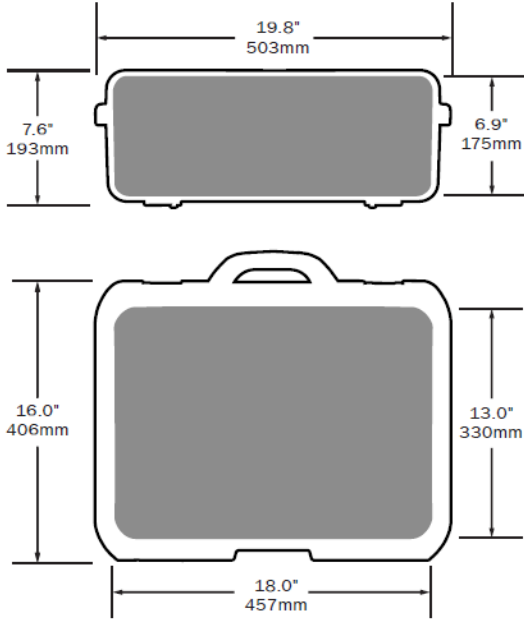

Warranty

MCP6-LV-6H6 hoist controller is covered by a 2-year manufacturer's warranty. For extended warranty conditions, please contact the manufacturer at sales@srs-group.com.

The warranty covers the original factory installed components of the controller and their correct functioning.

The warranty voids if any part or replacement component is installed or modified without authorization from the manufacturer and/or the internal circuit is tampered or modified and/or the controller is operated outside of normal using conditions – electrical power supply is not conforming or there is connection error or mechanical damage of controller, including overload and improper use.

The manufacturer always helps with the repair of each unit.



DECLARATION OF CONFORMITY

According to the specification of Machinery Directive 2006/42/CE, Annex II A:

Name of producer: SRS Group s.r.o.
Address of producer: Rybníčná 38/B
821 07 Bratislava
Slovakia

Declares that the product

Name of product: **MCP6**
Type: **MCP6-LV-6H6**
Year of construction: **2017**

Corresponds with the following harmonized standards:

Safety: EN 60065
EN 60950
EN 60204-1
EN 13850
EN 12100-2
EMC: EN55103-1, resp. EN55103-2

And is in compliance with following requirements:

Machinery directive: 2006/42/CE
Low Voltage directive: 2014/35/CE
Electromagnetic compatibility directive: 2014/30/CE

Bratislava, 27.6.2017

SRS Group s.r.o.
Rybníčná 38/B
821 07 Bratislava
Slovak Republic
SK 2022726629
IČO: 44520433
DIČ: 2022726629

SRS Group s.r.o.

Copyright 2017 SRS Group, s.r.o. | Specifications subject to change without notice.
Document: MCP6-LV-6H6_en_manual_M280.doc | Version 3.0 | Actual as of: 3 February
2020



SRS Group s.r.o.

Rybnicna 38/B | 831 07 Bratislava | Slovakia

Phone: +421 2 32 661 800

Email: sales@srs-group.com | www.srs-group.com

